

Item Number Format: 1.5TH- "A" - "B"

Examples: 1.5TH-1-.1875  
1.5TH-25MM-9MM

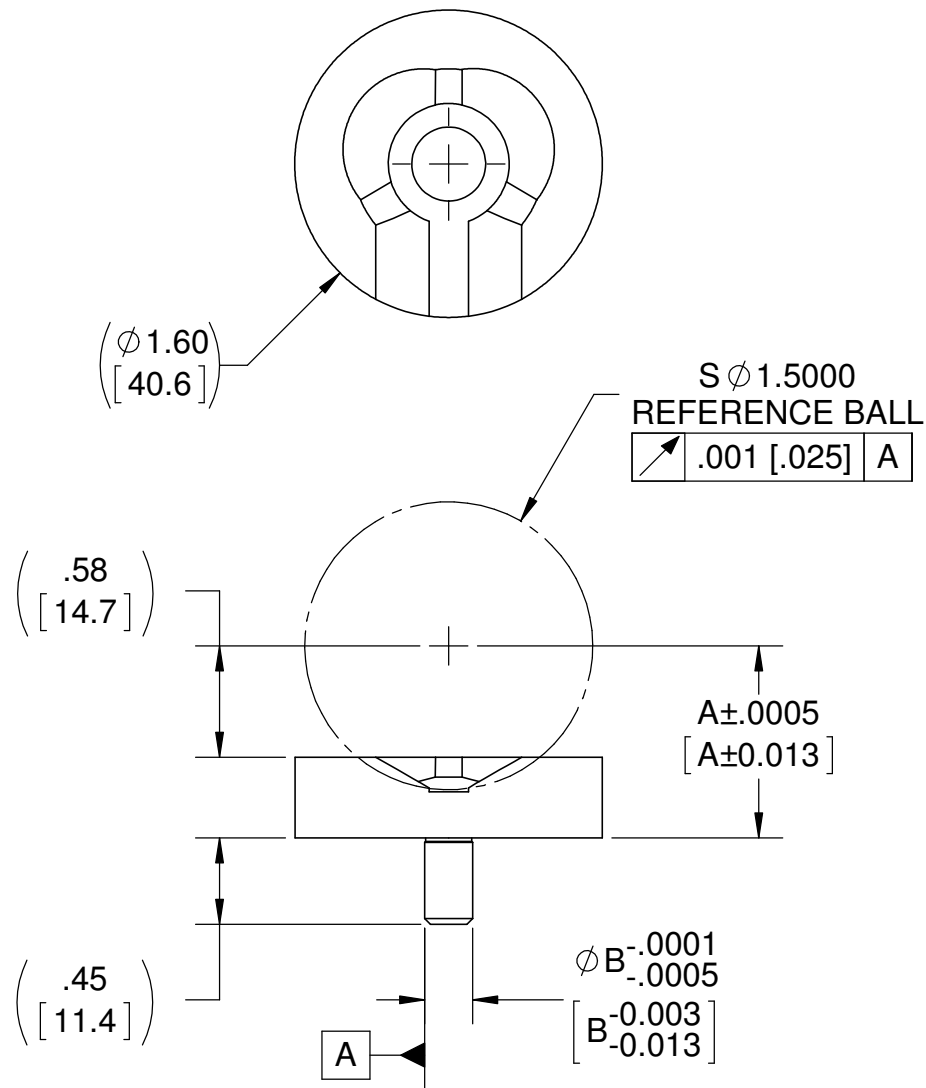
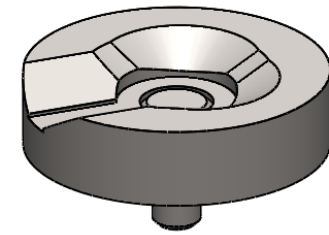

DIMENSIONS:

INCH X.XX  
MM [X.XX]  
REFERENCE (X.XX)



Brunson Instrument Company  
8000 E. 23rd Street  
Kansas City, MO 64129

Tel: 800-445-9405  
Fax: 816-241-1945  
Email: Sales@Brunson.us

TITLE: 1.5TH SERIES SMR ADAPTERS

MATERIAL: STAINLESS STEEL

HARDNESS: HRC 42-45

FINISH: MACHINED

WEIGHT (ESTIMATED)

0.215 LBS

SIZE

**A**

DATE: 1/9/2014

SCALE: 1:1

**PROPRIETARY AND CONFIDENTIAL**  
THE INFORMATION CONTAINED IN THIS  
DRAWING IS THE SOLE PROPERTY OF BRUNSON  
INSTRUMENT COMPANY. ANY REPRODUCTION  
IN PART OR AS A WHOLE WITHOUT THE WRITTEN  
PERMISSION OF BRUNSON INSTRUMENT  
COMPANY IS PROHIBITED.