

Item Number Format: 1.5TH-M-"A"-"B"

Examples: 1.5TH-M-1-.125
1.5TH-M-25MM-11MM

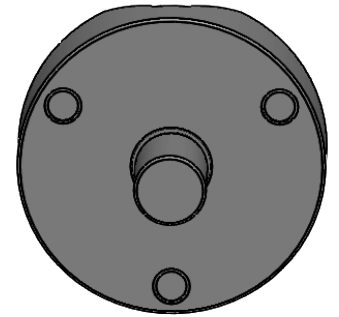
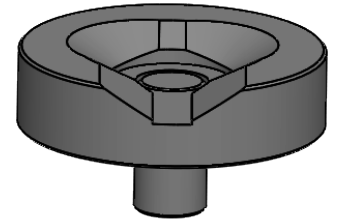
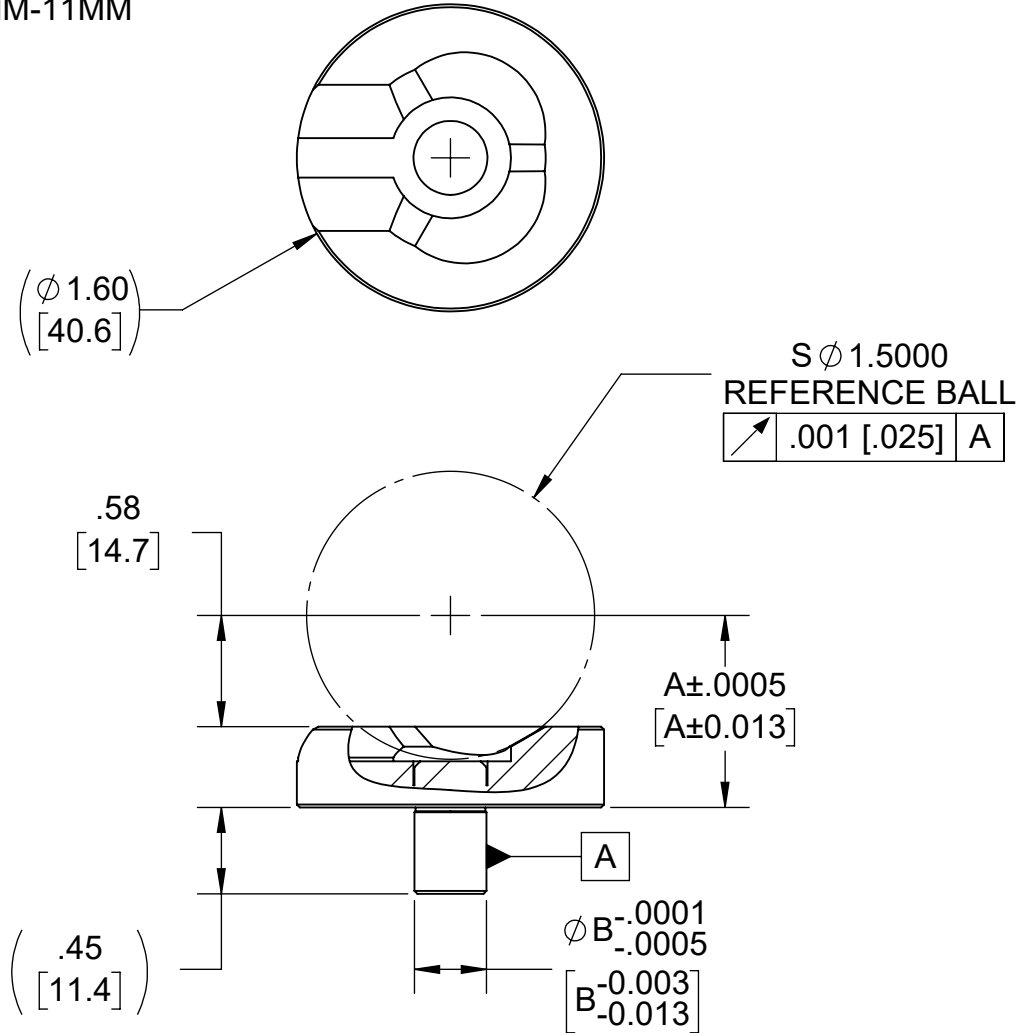

DIMENSIONS:

INCH X.XX
MM [X.XX]
REFERENCE (X.XX)

PROPRIETARY AND CONFIDENTIAL
THE INFORMATION CONTAINED IN THIS DRAWING
IS THE SOLE PROPERTY OF BRUNSON INSTRUMENT
COMPANY. ANY REPRODUCTION IN PART OR AS
A WHOLE WITHOUT THE WRITTEN PERMISSION OF
BRUNSON INSTRUMENT COMPANY IS PROHIBITED.



Brunson Instrument Company
8000 E. 23rd Street
Kansas City, MO 64129

Tel: 800-445-9405
Fax: 816-241-1945
Email: Sales@Brunson.us

TITLE: 1.5TH-M SERIES MAGNETIC BASE SMR ADAPTER

MATERIAL: STAINLESS STEEL

HARDNESS: HRC 42-45

FINISH: MACHINED

WEIGHT (ESTIMATED)

0.222 LBS

SIZE

A

DATE: 1/13/2014

SCALE: 3:1